

# PRINCETON MUNICIPAL LIGHT DEPARTMENT

168 WORCESTER ROAD PRINCETON, MA 01541



## Requirements for Interconnection of Non-Utility Generators And Distributed Generation

Revised April 2026  
Revised August 2023  
Revised November 2018  
Revised July 2017  
Enacted June 2008



# PRINCETON MUNICIPAL LIGHT DEPARTMENT

## Requirements for Interconnection of Non-Utility Generators and Distributed Generation

### TABLE OF CONTENTS

<b>1.0 Introduction.....</b>	<b>1</b>
1.1 Applicability .....	1
1.2 Definitions .....	1
1.3 Forms and Agreements .....	3
<b>2.0 Basic Understandings .....</b>	<b>4</b>
<b>3.0 Process Overview .....</b>	<b>5</b>
<b>4.0 Interconnection Requirements .....</b>	<b>6</b>
4.1 General Design Considerations.....	6
4.1.1 Transient Voltage Conditions .....	6
4.1.2 Noise and Harmonics.....	6
4.1.3 Frequency .....	6
4.1.4 Voltage Level.....	6
4.1.5 Machine Reactive Capability.....	6
4.2 Protection Requirements.....	7
4.2.1 General Requirements.....	7
4.2.2 Protection Requirements.....	7
4.2.2.1 Inverter-Based Facilities <10kW.....	9
4.2.2.2 Non-Inverter Based Facilities >10kW.....	10
4.2.2.2.1 General Requirements.....	10
4.2.2.2.2 Requirements for Induction and Synchronous Generator Facilities.....	10
4.2.2.2.3 Additional Requirements for Induction Generator Facilities .....	12
4.2.3 Protection System Testing and Maintenance .....	12
4.2.4 Protection Requirements – Momentary Paralleling of Standby Generators.....	12
4.2.5 Protection System Changes.....	13
<b>5.0 Responsibility for Costs of Interconnecting a Facility .....</b>	<b>14</b>
5.1 Review and Study Costs .....	14
5.2 Interconnection Equipment Costs .....	14
5.3 System Modification Costs.....	14
5.4 Separation of Costs.....	14
5.5 Normal Payment Procedure .....	14
5.6 Security and Creditworthiness .....	14
<b>6.0 Operating Requirements .....</b>	<b>15</b>
6.1 General Operating Requirements.....	15
6.2 No Adverse Effects; Non-interference.....	15
6.3 Safe Operations and Maintenance .....	15
6.4 Access.....	15
6.4.1 PMLD and Interconnecting Customer Representatives.....	15
6.4.2 PMLD Right to Access PMLD-Owned Facilities and Equipment .....	15
6.4.3 Right to Review Information .....	16
<b>7.0 Disconnection.....</b>	<b>17</b>
7.1 Temporary Disconnection.....	17
7.2 Permanent Disconnection .....	17
<b>8.0 Metering, Monitoring, and Communication .....</b>	<b>18</b>
8.1 Metering, Related Equipment and Billing Options.....	18
8.2 Additional Monitoring and Communication Requirements .....	19
<b>9.0 Insurance Requirements .....</b>	<b>20</b>
9.1 Insurer Requirements and Endorsements.....	20
9.2 Evidence of Insurance.....	20



## **TABLE OF CONTENTS (continued)**

### **Exhibit A – Interconnection Applications**

DG Projects < 30kW AC

DG Projects >= 30kW

### **Exhibit B – Drawings**

-B1 - Single-Phase Inverter-Based (<30kW)

-B2 – Single-Phase 30 to 60kW

-B3 – Three-Phase 60kW to 499kW

-B4 – Three-Phase (greater than 499kW)

### **Exhibit C – Summary of Interconnection Requirements 1.0 Introduction**

# 1.0 Introduction

## 1.1 Applicability

This Document (“Requirements for Interconnection of Non-Utility Generators and Distributed Generation”) describes the process and requirements for an Interconnecting Customer to connect a power-generating facility to the Princeton Municipal Light Department (“PMLD”) Electric Power System (“EPS”), including discussion of technical and operating requirements, metering options, and other matters. PMLD reserves the right to "cap" the total capacity of all combined interconnected generators at 1% of PMLD's total load.

The procedure for paralleling to the PMLD EPS with back-up generation is described within Section 4.0 Interconnection Requirements.

If the Facility will always be isolated from the PMLD’s EPS, (i.e., it will never operate in parallel to the PMLD’s EPS), then these Requirements do not apply.

## 1.2 Definitions

The following words and terms shall be understood to have the following meanings when used in these Interconnection Requirements:

**Anti-Islanding:** Describes the ability of a Facility to avoid unintentional islanding through some form of active control technique.

**Area EPS:** The PMLD EPS. This term is used in the Institute of Electrical and Electronics Engineers (IEEE) Standard 1547-2018 (or later), “IEEE Standard for Interconnecting Distributed Resources with Electric Power Systems” (“IEEE Standard 1547-2018 (or later)”).

**PMLD:** Princeton Municipal Light Department (PMLD).

**PMLD EPS:** The electric power system owned, controlled or operated by the PMLD used to provide distribution service to its Customers.

**Customer:** PMLD’s retail customer; host site or premises, may be the same as Interconnecting Customer.

**Department:** The Massachusetts Department of Public Utilities (DPU).

**Detailed Impact Study & Engineering Review:** An engineering study, as defined in Section 5.1, will be conducted by the PMLD to determine substantial System Modifications to its EPS, resulting in project cost estimates for such modifications that will be required to provide the requested interconnection service.

**DG:** Distributed Generation.

**Facility:** A source of electricity owned by the Interconnecting Customer that is located on the Interconnecting Customer’s side of the Point of Common Coupling (PCC), and all facilities ancillary and appurtenant thereto, including interconnection equipment, which the Interconnecting Customer requests to interconnect to the PMLD EPS.

**FERC:** Federal Energy Regulatory Commission.

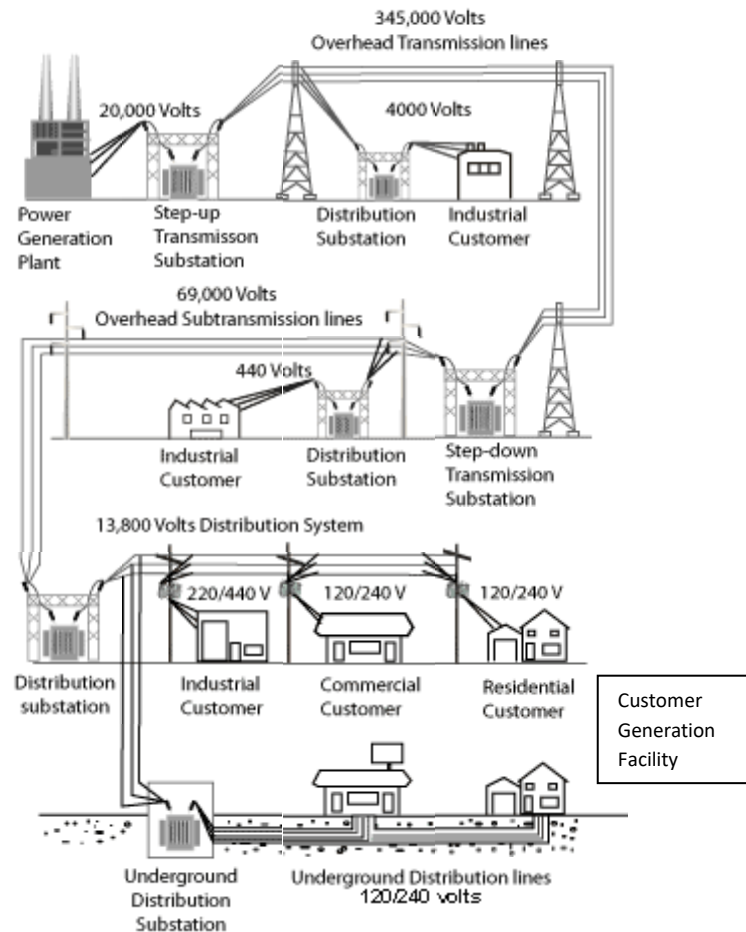

**Figure 1. Diagram of the Power Generation, Transmission and Distribution System**

**Good Utility Practice:** Any of the practices, methods and acts engaged in or approved by a significant portion of the electric utility industry during the relevant time period, or any of the practices, methods and acts which, in the exercise of reasonable judgment in light of the facts known at the time the decision was made, could have been expected to accomplish the desired result at a reasonable cost consistent with good business practices, reliability, safety and expedition. Good Utility Practice is not intended to be limited to the optimum practice, method, or act to the exclusion of all others, but rather to be acceptable practices, methods, or acts generally accepted in the region.

**In-Service Date:** The date on which the Facility and System Modifications (if applicable) are complete and ready for service, even if the Facility is not placed in service on or by that date.

**Interconnecting Customer:** Entity who owns and/or operates the Facility interconnected to the PMLD EPS.

**Interconnection Service Agreement:** An agreement for interconnection service, between the Interconnecting Customer and the PMLD.

**Islanding:** A situation where electrical power remains in a portion of the Power Generating Facility when the PMLD's transmission or distribution system has ceased providing power for whatever reason (emergency conditions, maintenance, etc.) Islanding may be intentional, such as when certain segregated loads in PMLD's premises are provided power by a Facility after being isolated from the PMLD EPS after a power failure. Unintentional Islanding, especially past the PCC, is prohibited and measures acceptable to PMLD must be in place to prevent its occurrence.

**ISO-New England, Inc. ("ISO-NE"):** The Independent System Operator established in accordance with the NEPOOL Agreement and applicable FERC approvals, which is responsible for managing the bulk power generation and transmission systems in New England.

**Isolated:** The state of operating the Facility when electrically disconnected from the PMLD EPS on the Interconnecting Customer's side of the PCC.

**Local EPS:** The customer premises within which are contained the Facility. This term is used in the IEEE Standard 1547-2018 (or later).

**Metering Point:** For meters that do not use instrument transformers, the point at which the billing meter is connected. For meters that use instrument transformers, the point at which the instrument transformers are connected.

**NEPOOL:** New England Power Pool.

#### **Generation Credit:**

PMLD offers a generation credit for over generation exported to the PMLD EPS. Details of this credit can be found on PMLD's website under the "Paying Your Bill" tab → "Rates" → "Solar Residential Rate". PMLD recommends customers size their system to meet their own goals and to understand how much of their generation will be coincident with their load. Customers will be charged full retail rates for all kilowatt hours delivered by PMLD.

**Non-Islanding:** Describes the ability of a Facility to avoid unintentional islanding through the operation of its interconnection equipment.

**NPCC:** Northeast Power Coordinating Council.

**On-Site Generating Facility:** A class of Interconnecting Customer-owned generating Facilities.

**Parallel:** The state of operating the Facility when electrically connected to the PMLD EPS (sometimes known as grid-parallel).

**Parties:** The PMLD and the Interconnecting Customer.

**Point of Common Coupling (PCC):** The point where the Interconnecting Customer's local electric power system connects to the PMLD EPS, such as the electric power revenue meter or premises service transformer. See the PMLD for the location at a particular Interconnecting Customer site.

**Point of Delivery:** A point on the PMLD EPS where the Interconnecting Customer makes capacity and energy available to the PMLD. The Point of Delivery shall be specified in the Interconnection Service Agreement.

**Point of Receipt:** A point on the PMLD EPS where the PMLD delivers capacity and energy to the Interconnecting Customer. The Point of Receipt shall be specified in the Interconnection Service Agreement.

**Radial Distribution Circuit:** Electrical service from an EPS consisting of one primary circuit extending from a single substation or transmission supply point arranged such that the primary circuit serves Interconnecting Customers in a particular local area.

**Screen(s):** Criteria by which the PMLD will determine if a proposed Facility's installation will adversely impact the PMLD EPS in the Processes as set forth in Section 3.0.

**System Modification:** Modifications or additions to distribution-related PMLD facilities that are integrated with the PMLD EPS for the benefit of the Interconnecting Customer.

**Unintentional Islanding:** A situation where the electrical power from the Facility continues to supply a portion of the PMLD EPS past the PCC when the PMLD's transmission or distribution system has ceased providing power for whatever reason (emergency conditions, maintenance, etc.).

**Witness Test:** The PMLD's right to witness the commissioning testing. Commissioning testing is defined in IEEE Standard 1547-2018 (or later).

### 1.3 Forms and Agreements

The following documents for the interconnection process are included as Exhibits:

1. Application Forms (Exhibit A)

2. Drawings (Exhibit B)

- Inverter-based DG Systems (up to 10kW)
- Single-Phase Non-Inverter Based DG System (up to 60kW)
- Three-Phase Non-Synchronous Generators (up to 60kW)
- 
- Three-Phase Synchronous Generators (60kW – 1000kW) Any drawings provided establish a level of minimum requirements. For individual units or total connected generation over 1MW (1,000kW), requirements for connections and protections will be determined on a case-by-case basis. PMLD may elect to provide up-front requirements or may choose to review and comment on the Customer's submittals, in accordance with these requirements.

## 2.0 Basic Understandings

Interconnecting Customer intends to install a Facility on the Customer's side of the PCC that will be connected electrically to the PMLD EPS and operate in parallel, synchronized with the voltage and frequency maintained by the PMLD during all operating conditions. It is the responsibility of the Interconnecting Customer to design, procure, install, operate, and maintain all necessary equipment on its property for connection to the PMLD EPS.

The Interconnecting Customer and the PMLD shall enter into an Interconnection Service Agreement to provide for parallel operation of an Interconnecting Customer's Facility with PMLD EPS. Third party ownership is strictly prohibited. The Interconnecting Customer must be a customer of PMLD or a subsidiary of PMLD.

The interconnection of the Facility with the PMLD EPS must be reviewed for potential impact on the PMLD EPS and meet the technical requirements in Section 4.0 and must be operated as described under Section 6.0. In order to meet these requirements, an upgrade or other modifications to the PMLD EPS may be necessary. Subject to the requirements contained in this Document, the PMLD or its Affiliate shall modify the PMLD EPS accordingly.

Unless otherwise specified, the PMLD will build and own, as part of the PMLD EPS, all facilities necessary to interconnect the PMLD EPS with the Facility up to and including terminations at the PCC. The Interconnecting Customer shall pay all System Modification costs. The Interconnecting Customer should consult the PMLD before designing, purchasing and installing any generation equipment, in order to verify the nominal utilization voltages, frequency, and phase characteristics of the service to be supplied, the capacity available, and the suitability of the proposed equipment for operation at the intended location. Attempting to operate a generator at other than its nameplate characteristics may result in unsatisfactory performance or, in certain instances, injury to personnel and/or damage to equipment.

The Interconnecting Customer will be responsible for ascertaining from the PMLD, and the PMLD will diligently cooperate in providing, the service characteristics of the PMLD EPS at the proposed PCC. The PMLD will in no way be responsible for damages sustained as a result of the Interconnecting Customer's failure to ascertain the service characteristics at the proposed PCC.

The Facility should operate in such a manner that does not compromise or conflict with, the safety or reliability of the PMLD EPS. The Interconnecting Customer should design its equipment in such a manner that faults or other disturbances on the PMLD EPS do not cause damage to the Interconnecting Customer's equipment.

Authorization to interconnect will be provided once the Interconnecting Customer has met all terms of the interconnection process as outlined herein. These Requirements do not cover general distribution service needed to serve the Interconnecting Customer.

PMLD's most common primary distribution voltage is 13.8 kV. The majority of the distribution circuits are "effectively grounded" and are used for four-wire distribution (phase to neutral) connected loads. Transmission voltages are 115 kV. Contact PMLD for information on the specific circuit that will serve an Interconnecting Customer's proposed facility. PMLD maintains effective grounding on most of its distribution systems as defined by IEEE Std. 142.

### 3.0 Process Overview

All proposed new sources of electric power without respect to generator ownership, dispatch control, or prime mover that plan to operate in parallel with the PMLD EPS must submit a completed application and pay the appropriate application fee to the PMLD with which it wishes to interconnect. See Section 5 for appropriate fee schedule. The application will be acknowledged by the PMLD, and the Interconnecting Customer will be notified of the application's completeness.

The Standard Process for review and approval is as follows:

#### INITIAL REVIEW PHASE

- a. The PMLD will conduct an initial review that includes a scoping meeting/discussion with the Interconnecting Customer (if necessary) to review the application. After the scoping meeting the PMLD will provide pertinent information such as:
  - The available fault current at the proposed location;
  - The existing peak loading on the lines in the general vicinity of the Facility;
  - The configuration of the distribution lines.
- b. PMLD provides a cost estimate for a Detailed Impact Study and Engineering Review (if necessary). An estimate of the time to complete the Impact Study will also be provided

#### IMPACT STUDY PHASE

- c. Once the Interconnecting Customer executes an Agreement and pays pursuant to the terms thereof, the PMLD will conduct the Impact Study and Engineering Review.
- d. If the PMLD determines, in accordance with Good Utility Practice, that the System Modifications to the PMLD EPS are not substantial, the Impact Study and Engineering Review will determine the scope and cost of the modifications as defined in Section 5.0. If the PMLD determines, in accordance with Good Utility Practice, that the System Modifications to the PMLD EPS are substantial, the Impact Study and Engineering Review will produce an estimate only for the modification costs. Customer to pay initial estimated costs and pay a true-up for actual costs.
- e. Upon completion of any necessary studies, the PMLD shall send the Interconnecting Customer an executable Interconnection Service Agreement including an estimate for any required System Modifications and reasonable Witness Test costs.

#### CONSTRUCTION PHASE

- f. Interconnecting Customer returns signed Interconnection Service Agreement and pays estimate prior to any PMLD construction work being done.
- g. Interconnecting Customer completes installation and PMLD completes System Modifications, if required.
- h. PMLD inspects completed installation for compliance with requirements and attends Witness Test, if required.
- i. Interconnecting Customer sends written notification of completion of installation to PMLD and intent to generate electricity. Commercial operation may begin with PMLD approval.

## **4.0 Interconnection Requirements**

### **4.1 General Design Considerations**

Interconnecting Customer shall design and construct the Facility in accordance with the applicable manufacturer's recommended maintenance schedule, in compliance with all aspects of the PMLD's requirement. Interconnecting Customer agrees to cause its Facility to be constructed in accordance with applicable specifications that meet or exceed those provided under this Section of these Requirements.

#### **4.1.1 Transient Voltage Conditions**

Because of unusual events in the PMLD's EPS, there will be transient voltage fluctuations, which will result in voltages exceeding the limits of the stated and standard ranges. These transient voltage fluctuations, which generally last only a few milliseconds, arise due to EPS disturbances including, but not limited to, lightning strikes, clearing of faults, and other switching operations. The magnitude of transient voltage fluctuations varies with EPS configuration, grounding methods utilized, local short circuit availability, and other parameters, which vary from point-to-point and from time-to-time on the distribution EPS.

The fluctuations may result in voltages exceeding the limits of the stated ranges and occur because of EPS disturbance, clearing of faults and other switching operations. These unavoidable transients are generally of too short duration and insufficient magnitude to have any adverse effects on general service applications. They may, however, cause malfunctions in equipment highly sensitive to voltage changes, and protective devices may operate to shut down such devices. The magnitude, duration and frequency of transient fluctuations will vary due to EPS configuration and/or circuit arrangement. In addition, disturbances of indeterminate magnitude and duration may occur on infrequent occasions due to short circuits, faults, and other unpredictable conditions. Transient voltages should be evaluated in the design of the Facility.

#### **4.1.2 Noise and Harmonics**

The introduction of abnormal noise/harmonics can cause abnormal neutral current flow, and excessive heating of electrical equipment. The permissible level of harmonics is dependent upon the voltage level and short circuit ratio at a given location. IEEE Standard 1547-2018 (or later) provides these levels at the PCC, along with IEEE-519 (latest edition). In requiring adherence to IEEE Standard 1547-2018 (or later) the PMLD is in no way making a recommendation regarding the level of harmonics that a given piece of equipment can tolerate nor is it making a recommendation as to the permissible level in the Interconnecting Customer's Facility.

#### **4.1.3 Frequency**

The interconnected electric power system in North America, which is maintained at 60 hertz ("Hz") frequency on its alternating current services, is subject to certain deviations. The usual maximum instantaneous deviation from the standard 60 Hz is  $\pm 2/10$  cycle ( $\pm 0.33\%$ ), except on infrequent occasions when the deviation may reach  $\pm 1/10$  cycle ( $\pm 0.17\%$ ). The usual normal deviation is approximately  $\pm 1/20$  cycle ( $\pm 0.083\%$ ). These conditions are subject to occur at any time of the day or night and should be considered in the design of the Facility. All are measured on a 60 Hz base.

#### **4.1.4 Voltage Level**

All electricity flow across the PCC shall be in the form of single-phase or three-phase 60 Hz alternating current at a voltage class determined by mutual agreement of the Parties. All voltage levels at the POI/PCC shall be in accordance with ANSI C84.1 Level A.

#### **4.1.5 Machine Reactive Capability**

Facilities less than 1 megawatt ("MW") will not be required to provide reactive capability, except as may be provided by the retail rate schedule under which the Customer takes service. All DG shall generate at unity (1.0) power factor, unless otherwise directed by the utility.

Facilities greater than or equal to 1 MW interconnected with the PMLD EPS may be required to provide reactive capability to regulate and maintain EPS voltage at the PCC as per ISO and NEPOOL (or their successors) requirements. The PMLD and NEPOOL shall establish a scheduled range of voltages to be maintained by the Facility. The reactive capability requirements shall be reviewed as part of the Impact Study and Engineering Review. Customer to contact agencies, including, but not limited to NEPOOL, ISO, NERC, NPCC, REMVEC and MMWEC (or their successors) and report findings in writing to PMLD prior

to the start of any construction work.

The power factor (PF) for Renewable Energy Sources must be measured at the point of interconnection, which is typically, but not always, the metering point and be in compliance with NEPOOL & ISO Load Power Factor (LPF) standards at all times, under all kW (real power) loading conditions.

## 4.2 Protection Requirements

### 4.2.1 General Requirements

Any Facility desiring to interconnect with the PMLD EPS or modify an existing interconnection must meet minimum specifications, where applicable, as set forth in the following documents and standards and requirements in this Section.

- IEEE Standard 1547-2018 (or later), “IEEE Standard for Interconnecting Distributed Resources with Electric Power Systems.”
- UL Standard 1741-SA, “Inverters, Converters and Charge Controllers for Use in Independent Power Systems.”
- IEEE Standard 929-2000, “IEEE Recommended Practice for Utility Interface of Photovoltaic (PV) Systems.”

The specifications and requirements listed herein are intended to mitigate possible adverse impacts caused by the Facility on the PMLD’s equipment and personnel and on other Interconnecting Customers of the PMLD. They are not intended to address protection of the Facility itself or its internal load. It is the responsibility of the Facility to comply with the requirements of all appropriate standards, codes, statutes and authorities to protect itself and its loads and workers.

The PMLD shall not be responsible for the protection of the Facility. The Facility shall be responsible for protection of its system against possible damage resulting from parallel operation with the PMLD so long as the PMLD adheres to Good Utility Practice. If requested by the Interconnecting Customer, the PMLD will provide system protection information for the line terminal(s) directly related to the interconnection. This protection information contained herein is provided exclusively for use by the Interconnecting Customer to evaluate protection of its Facility during parallel operation.

At its sole discretion, the PMLD may consider approving alternatives that satisfy the intent of the requirements contained in this Section.

### 4.2.2 Protection Requirements

All Facilities must meet performance requirements set forth in relevant sections of IEEE Standard 1547-2018 (or later). **The following italicized text is excerpted from IEEE Standard 1547- 2018. The numbering is also from IEEE Standard 1547-2018 (or later) and therefore is not in sequence with the “PMLD Requirements for Interconnection Non-Utility Generators and Distributed Generation” numbering.**

#### ***4.1.1 Voltage regulation***

*The DR [distributed resource] shall not actively regulate the voltage at the PCC [unless required by NEPOOL’s operating procedures]. The DR shall not cause the Area EPS service voltage at other Local EPSs to go outside the requirements of ANSI C84.1-1995, Range A.*

#### ***4.1.2 Integration with Area EPS grounding***

*The grounding scheme of the DR interconnection shall not cause over-voltages that exceed the rating of the equipment connected to the Area EPS and shall not disrupt the coordination of the ground fault protection on the Area EPS.*

#### ***4.1.3 Synchronization***

*The DR unit shall parallel with the Area EPS without causing a voltage fluctuation at the PCC greater than  $\pm 5\%$  of the prevailing voltage level of the Area EPS at the PCC, and meet the flicker requirements of 4.3.2.*

#### ***4.1.8.2 Surge withstand performance***

*The interconnection system shall have the capability to withstand voltage and current surges in accordance with the environments defined in IEEE Std C62.41.2-2002 or IEEE C37.90.1-2002 as applicable.*

### ***4.2 Response to Area EPS abnormal conditions***

Abnormal conditions can arise on the Area EPS that require a response from the connected DR. This response contributes to the safety of utility maintenance personnel and the general public, as well as the avoidance of damage to connected equipment, including the DR. All voltage and frequency parameters specified in these subclauses shall be met at the PCC, unless otherwise stated.

**4.2.1 Area EPS faults**

The DR unit shall cease to energize the Area EPS for faults on the Area EPS circuit to which it is connected.

**4.2.2 Area EPS reclosing coordination**

The DR shall cease to energize the Area EPS circuit to which it is connected prior to reclosure by the Area EPS.

**4.2.3 Voltage**

The protection functions of the interconnection system shall detect the effective (rms) or fundamental frequency value of each phase-to-phase voltage, except where the transformer connecting the Local EPS to the Area EPS is a grounded wye-wye configuration, or single-phase installation, the phase-to-neutral voltage shall be detected. When any voltage is in a range given in Table 1, the DR shall cease to energize the Area EPS within the clearing time as indicated. Clearing time is the time between the start of the abnormal condition and the DR ceasing to energize the Area EPS. For DR less than or equal to 30 kW in peak capacity, the voltage set points and clearing times shall be either fixed or field adjustable. For DR greater than 30 kW the voltage set points shall be field adjustable.

The voltages shall be detected at either the PCC or the point of DR connection when any of the following conditions exist:

- (a) The aggregate capacity of DR systems connected to a single PCC is less than or equal to 30 kW,
- (b) the interconnection equipment is certified to pass a non-islanding test for the system to which it is to be connected,
- (c) the aggregate DR capacity is less than 50% of the total Local EPS minimum annual integrated electrical demand for a 15 minute time period, and export of real or reactive power by the DR to the Area EPS is not permitted.

**4.2.4 Frequency**

When the system frequency is in a range given in Table 2, the DR shall cease to energize the Area EPS within the clearing time as indicated. Clearing time is the time between the start of the abnormal condition and the DR ceasing to energize the Area EPS. For DR less than or equal to 30 kW in peak capacity, the frequency set points and clearing times shall be either fixed or field adjustable. For DR greater than 30 kW, the frequency set points shall be field adjustable.

Adjustable under-frequency trip settings shall be coordinated with Area EPS operations.

**Table II: Inverters’ Frequency Trip Settings**

Shall Trip Function	Required Settings		Comparison to IEEE Std 1547-2018 (2 <sup>nd</sup> ed.) default settings and ranges of allowable settings for Category I, Category II, and Category III		
	Frequency (Hz)	Clearing Time(s)	Frequency	Clearing Time(s)	Within ranges of allowable settings?
OF2	62.0	0.16	Identical	Identical	Yes
OF1	61.2	300.0	Identical	Identical	Yes
UF1	58.5	300.0	Identical	Identical	Yes
UF2	56.5	0.16	Identical	Identical	Yes

**4.2.5 Loss of synchronism**

Loss of synchronism protection is not required except as necessary to meet 4.3.2.

**4.2.6 Reconnection to Area EPS**

After an Area EPS disturbance, no DR reconnection shall take place until the Area EPS voltage is within Range B of ANSI C84.1-1995, Table 1, and frequency range of 59.3Hz to 60.5Hz.

*The DR interconnection system shall include an adjustable delay (or a fixed delay of five minutes) that may delay reconnection for up to five minutes after the Area EPS steady-state voltage and frequency are restored to the ranges identified above.*

#### **4.3.1 Limitation of dc injection**

*The DR and its interconnection system shall not inject dc current greater than 0.5% of the full rated output current at the point of DR connection.*

#### **4.3.2 Limitation of flicker induced by the DR**

*The DR shall not create objectionable flicker for other customers on the Area EPS.*

#### **4.3.3 Harmonics**

*When the DR is serving balanced linear loads, harmonic current injection into the Area EPS at the PCC shall not exceed the limits stated in Table 3 IEEE Std 1547-2018 (or later). The harmonic current injections shall be exclusive of any harmonic currents due to harmonic voltage distortion present in the Area EPS without the DR connected.*

#### **4.4.1 Unintentional islanding**

*For an unintentional island in which the DR energizes a portion of the Area EPS through the PCC, the DR interconnection system shall detect the island and cease to energize the Area EPS within two seconds of the formation of an island.*

### **4.2.2.1 Inverter-Based Facilities (30kW or less)**

- a. **External Disconnect Switch:** PMLD shall require an external disconnect switch (or comparable device by mutual agreement of the Parties) at the PCC with the PMLD or at another mutually agreeable point that is accessible to PMLD personnel at all times and that can be opened for isolation if the switch is required.

The switch shall be gang operated, have a visible break when open, be rated to interrupt the maximum generator output and be capable of being locked open, tagged and grounded on the PMLD side by PMLD personnel. The visible break requirement can be met by opening the enclosure to observe the contact separation. The PMLD shall have the right to open this disconnect switch in accordance with these Interconnection Requirements.

### **4.2.2.2 All Other Facilities (30kW-499kW and over)**

#### **4.2.2.2.1 General Requirements**

- a. **Non Export Power:** If the Parties mutually agree that non-export functionality will be part of the interconnection protection equipment then it will include one of the following:
  - (1) a reverse power relay with mutually agreed upon delay intervals, or
  - (2) a minimum power function with mutually agreed upon delay intervals, or
  - (3) other mutually agreeable approaches, for example, a comparison of nameplate rating versus certified minimum Customer premises load.
- b. The ISO-NE (or its successor) is responsible for assuring compliance with NPCC criteria. For the interconnection of some larger units, the NPCC criteria may additionally require:

**NPCC Protective Relaying Requirements:** The PMLD may require the Facility to be equipped with two independent, redundant relaying systems in accordance with NPCC criteria, where applicable, for the protection of the bulk power system if the interconnection is to the bulk power system or if it is determined that delayed clearing of faults within the Facility adversely affects the bulk power system.

**NPCC Requirements:** During system conditions where local area load exceeds system generation, NPCC Emergency Operation Criteria requires a program of phased automatic under frequency load shedding of up to 25% of area load to assist in arresting frequency decay and to minimize the possibility of system collapse. Depending on the point of connection of the Facility to the PMLD's EPS and in conformance with the NPCC Emergency Operating Criteria, the

Facility may be required to remain connected to the EPS during the frequency decline to allow the objectives of the automatic load shedding program to be achieved, or to otherwise provide compensatory load reduction, equivalent to the Facility's generation lost to the system, if the Interconnecting Customer elects to disconnect the Facility at a higher under-frequency set point. All NPCC reporting requirements and associated costs of reporting shall be completed and paid by the customer. Any additional NPCC reporting that PMLD must complete, due to the customer's generation shall be paid by the customer for all PMLD time and expenses for such reporting.

- c. **Disconnect Switch:** The Facility shall provide a disconnect switch (or comparable device mutually agreed upon by the Parties) at the point of Facility interconnection that can be opened for isolation. The switch shall be in a location easily accessible to PMLD personnel at all times. The switch shall be gang operated, have a visible break when open, be rated to interrupt the maximum generator output and be capable of being locked open, tagged and grounded on the PMLD side by PMLD personnel. The visible break requirement can be met by opening the enclosure to observe the contact separation. The PMLD shall exercise such right in accordance with Section 7.0 of these Requirements.

#### 4.2.2.2 Requirements for Induction and Synchronous Generator Facilities Interconnection

- a. **Interrupting Device** An interconnection Interrupting Device such as a circuit breaker shall be installed to isolate the Facility from the PMLD's EPS. If there is more than one Interrupting Device, this requirement applies to each one individually. The Interconnection Interrupting Device must be capable of interrupting the current produced when the Facility is connected out of phase with the PMLD's EPS, consistent with Section 4.1.8.3 of IEEE Standard 1547-2018 (or later) which states, "the interconnection system paralleling-device shall be capable of withstanding 220% of the interconnection system rated voltage."
- b. **Synchronizing Devices:** The Interconnecting Customer shall designate one or more Synchronizing Devices such as motorized breakers, contactor/breaker combinations, or a fused contactor (if mutually agreeable) to be used to connect the Facility's generator to the PMLD's EPS. This Synchronizing Device could be a device other than the interconnection Interrupting Device. The Synchronizing Device must be capable of interrupting the current produced when the Facility is connected out of phase with the PMLD's EPS, consistent with Section 4.1.8.3 of IEEE Standard 1547-2018 (or later) which states, "the interconnection system paralleling-device shall be capable of withstanding 220% of the interconnection system rated voltage."
- c. **Transformers:** The PMLD reserves the right to specify the winding connections for the transformer between the PMLD's voltage and the Facility's voltage ("Step-Up Transformer") as well as whether it is to be grounded or ungrounded at the PMLD's voltage. In the event that the transformer winding connection is grounded-wye / grounded-wye the PMLD reserves the right to specify whether the generator stator is to be grounded or not grounded. The Interconnecting Customer shall be responsible for procuring equipment with a level of insulation and fault-withstand capability compatible with the specified grounding method.
- d. **Voltage relays:** Voltage relays shall be frequency compensated to provide a uniform response in the range of 40 to 70 Hz.
- e. **Protective Relaying Redundancy:** For induction generators greater than 1/15 of on-site minimum verifiable load that is not equipped with on-site capacitors or that is greater than 200 kW, and for all synchronous generators, protective relays utilized by the Facility shall be sufficiently redundant and functionally separate so as to provide adequate protection, consistent with PMLD practices and standards, upon the failure of any one component.
- f. **Protective Relay Hard-Wire Requirement:** Unless authorized otherwise by the PMLD, protective relays must be hardwired to the device they are tripping. Further, interposing computer or programmable logic controller or the like is not permitted in the trip chain between the relay and the device being tripped.
- g. **Protective Relay Supply:** Where protective relays are required in this Section, their control circuits shall be DC powered from a battery/charger system or a UPS. Solid-state relays shall be self-powered, or DC powered from a battery/charger system or a UPS. If the Facility uses a PMLD-acceptable non-latching interconnection contactor, AC powered relaying shall be allowed provided the relay and its method of application are fail safe, meaning that if the relay fails or if the voltage and/or frequency of its AC power source deviate from the relay's design requirements for power, the relay or a separate fail-safe power monitoring relay acceptable to the PMLD will immediately trip the generator by opening the coil circuit of the interconnection contactor.
- h. **Current Transformers ("CT"):** CT ratios and accuracy classes shall be chosen such that secondary current is less than 100 amperes and transformation errors are consistent with PMLD practices. CT's used for revenue class metering must have a secondary current of 20 amperes or less.

- i. **Voltage Transformers (“VT”) and Connections:** The Facility shall be equipped with a direct voltage connection or a VT, connected to the PMLD side of the Interrupting Device. The voltage from this VT shall be used in an interlock scheme, if required by the PMLD. For three-phase applications, a VT for each phase is required. All three phases must be sensed either by three individual relays or by one relay that contains three elements. If the voltage on any of the three phases is outside the bounds specified by the PMLD the unit shall be tripped.

If the Facility’s Step-Up Transformer is ungrounded at the PMLD voltage, this VT shall be a single three-phase device or three single-phase devices connected from each phase to ground on the PMLD’s side of the Facility’s Step-Up Transformer, rated for phase-to-phase voltage and provided with two secondary windings. One winding shall be connected in open delta, have a loading resistor to prevent ferro resonance, and be used for the relay specified in these requirements.

#### 4.2.2.2.3 Additional Requirements for Synchronous Generator Facilities

**Ungrounded Transformers:** If the Facility’s Step-Up Transformer connection is ungrounded, the Facility shall be equipped with a zero sequence over-voltage relay fed from the open delta of the three-phase VT.

**High-Speed Protection:** The Facility may be required to use high-speed protection if time-delayed protection would result in degradation in the existing sensitivity or speed of the protection systems on the PMLD’s EPS.

**Breaker Failure Protection:** The Facility may be required to be equipped to provide local breaker failure protection which may include direct transfer tripping to the PMLD’s line terminal(s) in order to detect and clear faults within the Facility that cannot be detected by the PMLD’s back-up protection.

**Communications Channels:** The Interconnecting Customer is responsible for procuring any communications channels necessary between the Facility and the PMLD’s stations, and for providing protection from transients and over-voltages at all ends of these communication channels. The Interconnecting Customer will also bear the ongoing cost to lease these communication channels. Examples include, but are not limited to, connection to a line using high-speed protection, transfer tripping, generators located in areas with low-fault currents, or

#### 4.2.3 Protection System Testing and Maintenance

The PMLD shall have the right to witness the commissioning testing as defined in IEEE Standard 1547-2018 (or later) at the completion of construction and to receive a copy of all test data. The Facility shall be equipped with whatever equipment is required to perform this test.

Testing typically includes, but is not limited to:

- CT and CT circuit polarity, ratio, insulation, excitation, continuity and burden tests,
- VT and VT circuit polarity, ratio, insulation and continuity tests,
- Relay pick-up and time delay tests,
- Functional breaker trip tests from protective relays,
- Relay in-service test to check for proper phase rotation and magnitudes of applied currents and voltages,
- Breaker closing interlock tests, and
- Paralleling and disconnection operation.

Prior to final approval by the PMLD or anytime thereafter, the PMLD reserves the right to test the generator relaying and control related to the protection of the PMLD's EPS at the customer’s expense for all testing services.

The Interconnecting Customer has the full responsibility including cost for the proper periodic maintenance of its generating equipment and its associated control, protective equipment and interrupting devices. The Interconnecting Customer is responsible for the periodic maintenance of those relays, interrupting devices, control schemes, and batteries that involve the protection of the PMLD's EPS. A periodic maintenance program, mutually agreeable to both the PMLD and to the Interconnecting Customer is to be established in each case. The PMLD shall have the right to monitor the periodic maintenance performed.

For relays installed in accordance with the NPCC Criteria for the Protection of the Bulk Power System, maintenance intervals

shall be in accordance with such criteria.

#### **4.2.4 Protection Requirements – Momentary Paralleling of Standby Generators**

Protective relays to isolate the Facility for faults in the PMLD EPS are not required if the paralleling operation is automatic and takes place for less than one-half of a second. An Interrupting Device with a half-second timer (30 cycles) is required as a fail-safe mechanism.

Parallel operation of the Facility with the PMLD EPS shall be prevented when the PMLD's line is dead or out of phase with the Facility.

The control scheme for automatic paralleling must be submitted by the Interconnecting Customer for review and acceptance by the PMLD prior to the Facility being allowed to interconnect with the PMLD EPS.

#### **4.2.5 Protection System Changes**

The Interconnecting Customer must provide the PMLD with reasonable advance notice of any proposed changes to be made to the protective relay system, relay settings, operating procedures or equipment that affect the interconnection. The PMLD will determine if such proposed changes require re-acceptance of the interconnection per the requirements of this Section.

In the future, should the PMLD implement changes to the EPS to which the Facility is interconnected, the Interconnecting Customer will be responsible at its own expense for identifying and incorporating any necessary changes to its protection equipment. These changes to the Facility's protection equipment are subject to review and approval by the PMLD.

## 5.0 Responsibility for Costs of Interconnecting a Facility

### 5.1 Review and Study Costs

The Interconnecting Customer shall be responsible for the reasonably incurred costs of the review by the PMLD and any interconnection studies and engineering reviews conducted to determine the requirements of interconnecting a Facility with the PMLD EPS.

#### Distributed Generation Fee Schedules

	< 30 KW Residential Metering	≤100 KW Listed DG	≥100 KW Any DG
Application Fee (covers screens)	\$100	\$5/ KW Minimum \$100 Maximum \$500	\$5/ KW Minimum \$500 Maximum \$7,500
Supplemental Review or Additional Review (if applicable)	Actual Cost @ \$200 per hour	Actual Cost @ \$200 per hour	Actual Cost @ \$200 per hour
Standard Interconnection Initial Review	N/A	N/A	Included in Application fee (if applicable)
Impact Detailed Study (if required)	N/A	N/A	Actual Cost
Facility Upgrades	\$75	Actual Cost	Actual Cost
O&M	N/A	TBD	TBD
Witness Test	\$75	Actual Cost	Actual Cost
NET Meter	\$300	Actual Cost	Actual Cost

### 5.2 Interconnection Equipment Costs

The Interconnecting Customer shall be responsible for all costs associated with the installation and construction of the Facility and associated interconnection equipment on the Interconnecting Customer's side of the PCC.

### 5.3 System Modification Costs

The Interconnecting Customer shall also be responsible for all costs reasonably incurred by PMLD attributable to the proposed interconnection project in designing, engineering, constructing, operating and maintaining the System Modifications.

### 5.4 Separation of Costs

Should the PMLD combine the installation of System Modifications with additions to the PMLD's EPS to serve other customers or interconnecting customers, the PMLD shall not include the costs of such separate or incremental facilities in the amounts billed to the Interconnecting Customer for the System Modifications required.

The Interconnecting Customer shall only pay for that portion of the interconnection costs resulting solely from the System Modifications required to allow for safe, reliable parallel operation of the Facility with the PMLD EPS.

### **5.5 Normal Payment Procedure**

All application, study fees and System Modification costs are due in full prior to the execution of the work as outlined in these Requirements.

### **5.6 Security and Creditworthiness**

In order for the PMLD to agree to any payment plan where some work may be performed in advance of payment, the PMLD may require the Interconnecting Customer to provide evidence of creditworthiness.

### **5.7 Ongoing Costs**

All ongoing costs associated with the maintenance of the PMLD equipment will be billed directly to the Customer.

## **6.0 Operating Requirements**

The Interconnecting Customer shall also be responsible for ongoing costs incurred by PMLD for maintenance, testing, inspections, etc. as defined by the final agreement by the parties for the life of the project.

### **6.1 General Operating Requirements**

Interconnecting Customer shall operate and maintain the Facility in accordance with the applicable manufacturer's recommended maintenance schedule, in compliance with all aspects of the PMLD's Interconnection Requirements. The Interconnecting Customer will continue to comply with all applicable laws and requirements after interconnection has occurred. In the event the PMLD has reason to believe that the Interconnecting Customer's installation may be the source of problems on the PMLD EPS, the PMLD has the right to install monitoring equipment at a mutually agreed upon location to determine the source of the problems. If the Facility is determined to be the source of the problems, the PMLD may require disconnection and the Interconnecting Customer shall be responsible for all costs incurred by PMLD.

### **6.2 No Adverse Effects; Non-interference**

PMLD shall notify Interconnecting Customer if there is evidence that the operation of the Facility could cause disruption or deterioration of service to other Customers served from the same PMLD EPS or if operation of the Facility could cause damage to PMLD EPS. The deterioration of service could be, but is not limited to, harmonic injection in excess of IEEE Standard 1547-2018 (or later), as well as voltage fluctuations caused by large step changes in loading at the Facility.

The PMLD will operate the EPS in such a manner so as to not unreasonably interfere with the operation of the Facility. The Interconnecting Customer will protect itself from normal disturbances propagating through the PMLD EPS, and such normal disturbances shall not constitute unreasonable interference unless the PMLD has deviated from Good Utility Practice. Examples of such disturbances could be, but are not limited to, single-phasing events, voltage sags from remote faults on the PMLD EPS, and outages on the PMLD EPS.

### **6.3 Safe Operations and Maintenance**

Each Party shall operate, maintain, repair, and inspect, and shall be fully responsible for, the facility or facilities that it now or hereafter may own unless otherwise specified in this Document. Each Party shall be responsible for the maintenance, repair and condition of its respective lines and appurtenances on their respective side of the PCC. The PMLD and the Interconnecting Customer shall each provide equipment on its respective side of the PCC that adequately protects the PMLD's EPS, personnel, and other persons from damage and injury.

### **6.4 Access**

The PMLD shall have access to the disconnect switch of the Facility at all times.

#### **6.4.1 PMLD and Interconnecting Customer Representatives**

Each Party shall provide and update as necessary the telephone number that can be used at all times to allow either Party to report an emergency.

#### **6.4.2 PMLD Right to Access PMLD-Owned Facilities and Equipment**

If necessary for the purposes of this Interconnection Requirements and in the manner it describes, the Interconnecting Customer shall allow the PMLD access to the PMLD's equipment and the PMLD's facilities located on the Interconnecting Customer's or Customer's premises. To the extent that the Interconnecting Customer does not own all or any part of the property on which the PMLD is required to locate its equipment or facilities to serve the Interconnecting Customer under this Interconnection Requirements, the Interconnecting Customer shall secure and provide in favor of the PMLD the necessary rights to obtain access to such equipment or facilities, including easements if the circumstances so require.

#### **6.4.3 Right to Review Information**

The PMLD shall have the right to review and obtain copies of Interconnecting Customer's operations and maintenance records, logs, or other information such as, unit availability, maintenance outages, circuit breaker operation requiring manual reset, relay targets and unusual events pertaining to Interconnecting Customer's Facility or its interconnection with the PMLD EPS. This information will be treated as customer-confidential.

## **7.0 Disconnection**

### **7.1 Temporary Disconnection**

- a. **Emergency Conditions:** PMLD shall have the right to immediately and temporarily disconnect the Facility without prior notification in cases where, in the reasonable judgment of PMLD continuance of such service to Interconnecting Customer is imminently likely to (i) endanger persons or damage property or (ii) cause a material adverse effect on the integrity or security of, or damage to, PMLD EPS or to the electric systems of others to which the PMLD EPS is directly connected. PMLD shall notify Interconnecting Customer promptly of the emergency condition.

Interconnecting Customer shall notify PMLD promptly when it becomes aware of an emergency condition that affects the Facility that may reasonably be expected to affect the PMLD EPS. To the extent information is known, that notification shall describe the emergency condition, the extent of the damage or deficiency, or the expected effect on the operation of both Parties' facilities and operations, its anticipated duration and the necessary corrective action.

- b. **Routine Maintenance, Construction and Repair:** PMLD shall have the right to disconnect the Facility from the PMLD EPS when necessary for routine maintenance, construction and repairs on the PMLD EPS. The PMLD shall provide the Interconnecting Customer reasonable notice, if possible.

Any additional notification requirements will be specified by mutual agreement in the Interconnection Service Agreement.

- c. **Forced Outages:** During any forced outage, PMLD shall have the right to suspend interconnection service to effect immediate repairs on the PMLD EPS; provided, however, PMLD shall use reasonable efforts to provide the Interconnecting Customer with prior notice. Where circumstances do not permit such prior notice to Interconnecting Customer, PMLD may interrupt Interconnection Service and disconnect the Facility from the PMLD EPS without such notice.
- d. **Non-Emergency Adverse Operating Effects:** The PMLD may disconnect the Facility if the Facility is having an adverse operating effect on the PMLD EPS or other customers that is not an emergency.
- e. **Modification of the Facility:** PMLD shall notify Interconnecting Customer if there is evidence of a material modification to the Facility and shall have the right to immediately suspend interconnection service in cases where such material modification has been implemented without prior written authorization from the PMLD.
- f. **Re-connection:** Any curtailment, reduction or disconnection shall continue only for so long as reasonably necessary.

The Interconnecting Customer and the PMLD shall cooperate with each other to restore the Facility and the PMLD EPS, respectively, to their normal operating state as soon as reasonably practicable following the cessation or remedy of the event that led to the temporary disconnection.

## **7.2 Permanent Disconnection**

The Interconnecting Customer has the right to permanently disconnect at any time after 30 days written notice to the PMLD.

The PMLD may permanently disconnect the Facility upon termination of the Interconnection Service Agreement in accordance with the terms thereof.

## **8.0 Metering, Monitoring, and Communication**

This Section sets forth the rules, procedures and requirements for metering, monitoring and communication between the Facility and the PMLD EPS where the Facility exports power or is net metered or is otherwise subject to NEPOOL requirements. Interconnecting Customer will be responsible for all reasonable and necessary costs incurred by PMLD for the purchase, installation, operation, maintenance, testing, repair and replacement of metering and data acquisition equipment.

### **8.1 Metering, Related Equipment and Billing Options**

The PMLD shall furnish, read and maintain all revenue metering equipment. The Interconnecting Customer shall furnish and maintain all meter mounting equipment such as or including meter sockets, test switches, conduits, and enclosures. Except as provided below, the PMLD shall own the meter and the Interconnecting Customer shall pay to the PMLD a monthly charge to cover taxes, meter maintenance, incremental reading and billing costs, the allowable return on the invoice cost of the meter and the depreciation of the meter.

The Interconnecting Customer shall provide suitable space within the Facility for installation of the metering, and communication equipment at no cost to the PMLD. All meter enclosures shall have a red plastic placard with white embossed writing attached by rivets either directly above or below the meter. The embossed wording will be "Caution, Interconnected Generator". The attached placard will be a minimum of 1 1/2" high and 3" wide. The placard will be provided by PMLD to the customer/installer and be properly installed prior to PMLD's final witness test and approval.

All metering equipment installed pursuant to this Interconnection Requirements and associated with the Facility shall be routinely tested by the PMLD at Interconnecting Customer's expense, in accordance with applicable PMLD and/or ISO-NE criteria, rules and standards. If, at any time, any metering equipment is found to be inaccurate by a margin greater than that allowed under applicable criteria, rules and standards, the PMLD shall cause such metering equipment to be made accurate or replaced. The cost to repair or replace the meter shall be done by the PMLD, if the PMLD owns the meter. Meter readings for the period of inaccuracy shall be adjusted so far as the same can be reasonably ascertained.

Each Party shall comply with any reasonable request of the other concerning the sealing of meters, the presence of a representative of the other Party when the seals are broken and the tests are made, and other matters affecting the accuracy of the measurement of electricity delivered from the Facility. If either Party believes that there has been a meter failure or stoppage, it shall immediately notify the other.

If the Metering Point and the Point of Receipt or Point of Delivery are not at the same location, the metering equipment shall record delivery of electricity in a manner that accounts for losses occurring between the Metering Point and the Point of Receipt or Point of Delivery.

The type of metering equipment to be installed at a Facility is dependent on the Category (size) of the Facility.

**Units over 30 kW:** Will be equipped with a bi-directional meter. Such meter may have remote access capability and may be an interval meter based on Customer rate class.

**Units over 499kW:** Shall be equipped with bi-directional, interval meters with remote access. In addition, Facilities which are required by ISO/NEPOOL Operating Procedure No. 18 to provide communication equipment and to supply accurate and reliable information to system operators regarding metered values for MW, MVAR, volt, amp, frequency, breaker status and all other information deemed necessary by ISO-NE and the NEPOOL Satellite (REMVEC). All costs for remote access, remote communications, monitoring, etc. will be paid for by the Interconnection Customer.

## **8.2 Additional Monitoring and Communication Requirements**

As the amount of distributed generation on the PMLD EPS grows significantly, additional monitoring and communication may be required by the Massachusetts DPU and need to be installed at the Customer's expense.

## **9.0 Insurance Requirements**

Insurance requirements will be set forth by the PMLD for the Interconnecting Customer to maintain, on an individual project basis, given the size, cost and complexity of the Distributed Generation project.

No insurance is required for Facilities less than or equal to ten (10) kW. However, the PMLD recommends that the Interconnecting Customer obtain adequate insurance to cover potential liabilities.

### **9.1 Insurer Requirements and Endorsements**

All required insurance shall be carried by reputable insurers qualified to underwrite insurance in MA having a Best Rating of "A-". In addition, all insurance shall,

- (a) include PMLD as an additional insured;
- (b) contain a severability of interest clause or cross-liability clause;
- (c) provide that PMLD shall not incur liability to the insurance carrier for payment of premium for such insurance; and
- (d) provide for thirty (30) calendar days' written notice to PMLD prior to cancellation, termination, or material change of such insurance;

### **9.2 Evidence of Insurance**

Evidence of the insurance required shall state that coverage provided is primary and is not in excess to or contributing with any insurance or self-insurance maintained by Interconnecting Customer.

The Interconnecting Customer is responsible for providing the PMLD with evidence of insurance in compliance with this Interconnection Requirements on an annual basis.

Prior to the PMLD commencing work on System Modifications, the Interconnecting Customer shall have its insurer furnish to the PMLD certificates of insurance evidencing the insurance coverage required.

**PRINCETON MUNICIPAL LIGHT DEPARTMENT**  
**Non-Utility Generation Interconnection Application**  
**for Facilities Less Than 30kW AC**

**Page 1 of 1**

**Contact Information:**

Legal Name and address of Interconnecting Customer (or, Company name, if appropriate)

Customer or Company Name (print): \_\_\_\_\_ Contact Person, if Company: \_\_\_\_\_

Mailing Address: \_\_\_\_\_

City: \_\_\_\_\_ State: \_\_\_\_\_ Zip Code: \_\_\_\_\_

Telephone (Daytime): \_\_\_\_\_ (Evening): \_\_\_\_\_

Facsimile Number: \_\_\_\_\_ E-Mail Address: \_\_\_\_\_

**Alternative Contact Information** (e.g., system installation contractor or coordinating company, if appropriate):

Name: \_\_\_\_\_

Mailing Address: \_\_\_\_\_

City: \_\_\_\_\_ State: \_\_\_\_\_ Zip Code: \_\_\_\_\_

Telephone (Daytime): \_\_\_\_\_ (Evening): \_\_\_\_\_

Facsimile Number: \_\_\_\_\_ E-Mail Address: \_\_\_\_\_

**Electrical Contractor Contact Information** (if appropriate):

Name: \_\_\_\_\_ Telephone: \_\_\_\_\_

Mailing Address: \_\_\_\_\_

City: \_\_\_\_\_ State: \_\_\_\_\_ Zip Code: \_\_\_\_\_

**Ownership Information** (include % ownership by any electric utility): \_\_\_\_\_

**Facility Information:**

Address of Facility: \_\_\_\_\_

City: \_\_\_\_\_ State: \_\_\_\_\_ Zip Code: \_\_\_\_\_

Electric Service Company: \_\_\_\_\_ Account Number (if available): \_\_\_\_\_

Inverter Manufacturer: \_\_\_\_\_ Model Name and Number: \_\_\_\_\_ Quantity: \_\_\_\_\_

Nameplate Rating: \_\_\_\_\_ (kW) \_\_\_\_\_ (kVA) \_\_\_\_\_ (AC Volts) Single \_\_\_\_\_ or Three Phase \_\_\_\_\_

System Design Capacity: \_\_\_\_\_ (kW) \_\_\_\_\_ (kVA)

Prime Mover: Photovoltaic      Reciprocating Engine      Fuel Cell      Turbine      Other \_\_\_\_\_

Energy Source: Solar      Wind      Hydro      Diesel      Natural Gas      Fuel Oil      Other \_\_\_\_\_

UL 1741-SA Listed? Yes \_\_\_\_\_ No \_\_\_\_\_

Estimated Install Date: \_\_\_\_\_ Estimated In-Service Date: \_\_\_\_\_

**Customer Signature**

I hereby certify that, to the best of my knowledge, all of the information provided in this application is true and I agree to the PMLD Standard Terms and Conditions:

Interconnecting Customer Signature: \_\_\_\_\_ Title: \_\_\_\_\_ Date: \_\_\_\_\_

*Please attach any documentation provided by the inverter manufacturer describing the inverter's UL 1741-SA listing.*

**PRINCETON MUNICIPAL LIGHT DEPARTMENT**  
**Non-Utility Generation Interconnection Application**  
**for Facilities Greater Than or Equal To 30kW AC**

**Page 1 of 4**

**Contact Information:**

Legal Name and address of Interconnecting Customer (or, Company name, if appropriate)

Customer or Company Name (print): \_\_\_\_\_ Contact Person, if Company: \_\_\_\_\_

Mailing Address: \_\_\_\_\_

City: \_\_\_\_\_ State: \_\_\_\_\_ Zip Code: \_\_\_\_\_

Telephone (Daytime): \_\_\_\_\_ (Evening): \_\_\_\_\_

Facsimile Number: \_\_\_\_\_ E-Mail Address: \_\_\_\_\_

**Alternative Contact Information** (e.g., system installation contractor or coordinating company, if appropriate):

Name: \_\_\_\_\_

Mailing Address: \_\_\_\_\_

City: \_\_\_\_\_ State: \_\_\_\_\_ Zip Code: \_\_\_\_\_

Telephone (Daytime): \_\_\_\_\_ (Evening): \_\_\_\_\_

Facsimile Number: \_\_\_\_\_ E-Mail Address: \_\_\_\_\_

**Generating Facility Information:**

Address of Facility: \_\_\_\_\_

City: \_\_\_\_\_ State: \_\_\_\_\_ Zip Code: \_\_\_\_\_

Electric Service Company: \_\_\_\_\_ Account Number (if available): \_\_\_\_\_

Type of Generating Unit: Synchronous \_\_\_\_\_ Induction \_\_\_\_\_ Inverter \_\_\_\_\_

Manufacturer: \_\_\_\_\_ Model: \_\_\_\_\_

Nameplate Rating: \_\_\_\_\_ (kW) \_\_\_\_\_ (kVAr) \_\_\_\_\_ (Volts) Single \_\_\_\_\_ or Three Phase \_\_\_\_\_

Prime Mover: Recip Engine \_\_\_ Fuel Cell \_\_\_ Gas Turb \_\_\_ Steam Turb \_\_\_ Microturbine \_\_\_ PV \_\_\_ Other \_\_\_\_\_

Energy Source: Solar \_\_\_ Wind \_\_\_ Hydro \_\_\_ Diesel \_\_\_ Natural Gas \_\_\_ Fuel Oil \_\_\_ Other \_\_\_\_\_

UL 1741-SA Listed? Yes \_\_\_ No \_\_\_ Need an air quality permit from DEP? Yes \_\_\_ No \_\_\_ Not Sure

\_\_\_\_\_

If Yes, have you applied for it? Yes \_\_\_ No \_\_\_

Planning to Export Power? Yes \_\_\_ No \_\_\_

A Cogeneration Facility? Yes \_\_\_ No \_\_\_

Anticipated Export Power Purchaser: \_\_\_\_\_

Export From? Simultaneous Purchase/Sale \_\_\_\_\_ Net Purchase/Sale \_\_\_\_\_ Net Metering \_\_\_\_\_ Other \_\_\_\_\_

Est. Install Date: \_\_\_\_\_ Est. In-Service Date: \_\_\_\_\_ Agreement Needed by \_\_\_\_\_

**Application Process:**

I hereby certify that, to the best of my knowledge, all of the information provided in this application is true:

Interconnecting Customer Signature: \_\_\_\_\_ Title: \_\_\_\_\_ Date: \_\_\_\_\_

The information provided in this application is complete:

Company Signature: \_\_\_\_\_ Title: \_\_\_\_\_ Date: \_\_\_\_\_



**Generating Facility Technical Detail:**

List components of the generating facility that are currently certified and/or listed to national standards

Equipment Type	Manufacturer	Model	National Standard
1. _____	_____	_____	_____
2. _____	_____	_____	_____
3. _____	_____	_____	_____
4. _____	_____	_____	_____
5. _____	_____	_____	_____
6. _____	_____	_____	_____

Total Number of Generating Units in Facility? \_\_\_\_\_

Generating Unit Power Factor Rating: \_\_\_\_\_

Max Adjustable Leading Power Factor? \_\_\_\_\_ Max Adjustable Lagging Power Factor? \_\_\_\_\_

**Generating Characteristic Data (for all inverter-based machines)**

Max Design Fault Contribution Current? \_\_\_\_\_ Instantaneous \_\_\_\_\_ or RMS? \_\_\_\_\_

Harmonics Characteristics: \_\_\_\_\_

Start-up power requirements: \_\_\_\_\_

**Generator Characteristics Data (for all rotating machines)**

Rotating Frequency: \_\_\_\_\_ (rpm) Neutral Grounding Resistor (if applicable): \_\_\_\_\_

Additional Information for Synchronous Generating Units

Synchronous Reactance, X'd: \_\_\_\_\_ (PU) Transient Reactance, X'd: \_\_\_\_\_ (PU)

Subtransient Reactance, X'd: \_\_\_\_\_ (PU) Neg Sequence Reactance: \_\_\_\_\_ (PU)

Zero Sequence Reactance: \_\_\_\_\_ (PU) kVA Base: \_\_\_\_\_

Field Voltage: \_\_\_\_\_ (Volts) Field Current: \_\_\_\_\_ (Amps)

**Additional Information for Induction Generating Units**

Rotor Resistance, Rr \_\_\_\_\_ Stator Resistance, Rs: \_\_\_\_\_

Rotor Resistance, Xr \_\_\_\_\_ Stator Resistance, Xs: \_\_\_\_\_

Magnetizing Reactance, Xm: \_\_\_\_\_ Short Circuit Reactance, X'd: \_\_\_\_\_

Exciting Current: \_\_\_\_\_ Temperature Rise: \_\_\_\_\_

Frame Size: \_\_\_\_\_

Total Rotating Inertia, H: \_\_\_\_\_ Per Unit on kVA Base: \_\_\_\_\_

Reactive Power Required In Vars (No Load): \_\_\_\_\_

Reactive Power Required In Vars (Full Load): \_\_\_\_\_

**Additional Information for Induction Generating Units that are started by motoring**

Motoring Power: \_\_\_\_\_ (kW) Design Letter: \_\_\_\_\_



**Interconnection Equipment Technical Detail**

Will a transformer be used between the generator and the point of interconnection? Yes \_\_\_ No \_\_\_

Will the transformer be provided by Interconnecting Customer? Yes \_\_\_ No \_\_\_

**Transformer Data (if applicable, for Interconnecting Customer-Owned Transformer):**

Nameplate Rating: \_\_\_\_\_ (kVA) Single \_\_\_ or Three Phase \_\_\_

Transformer Impedance: \_\_\_\_\_ (%) on a \_\_\_\_\_ kVA Base

If Three Phase:

Transformer Primary: \_\_\_\_\_ (Volts) \_\_\_ Delta \_\_\_ Wye \_\_\_ Wye Grounded \_\_\_ Other

Transformer: \_\_\_\_\_ (Volts) \_\_\_ Delta \_\_\_ Wye \_\_\_ Wye Grounded \_\_\_ Other

**Transformer Fuse Data (if applicable, for Interconnecting Customer-Owned Fuse):**

(Attach copy of fuse manufacturer’s Minimum Melt & Total Clearing Time-Current Curves)

Manufacturer: \_\_\_\_\_ Type: \_\_\_\_\_ Size: \_\_\_\_\_ Speed: \_\_\_\_\_

**Interconnecting Circuit Breaker (if applicable):**

Manufacturer: \_\_\_\_\_ Type: \_\_\_\_\_ Load Rating: \_\_\_\_\_ Interrupting Rating: \_\_\_\_\_ Trip Speed: \_\_\_\_\_  
(Amps) (Amps) (Cycles)

**Interconnection Protective Relays (if applicable):**

(If microprocessor-controlled)

List of Functions and Adjustable Setpoints for the protective equipment or software:

	Setpoint Function	Minimum	Maximum
1.	_____	_____	_____
2.	_____	_____	_____
3.	_____	_____	_____
4.	_____	_____	_____
5.	_____	_____	_____
6.	_____	_____	_____

(If discrete components)

(Enclose copy of any proposed Time-Overcurrent Coordination Curves)

Manufacturer: \_\_\_\_\_ Type: \_\_\_\_\_ Style/Catalog No.: \_\_\_\_\_ Proposed Setting: \_\_\_\_\_

Manufacturer: \_\_\_\_\_ Type: \_\_\_\_\_ Style/Catalog No.: \_\_\_\_\_ Proposed Setting: \_\_\_\_\_

Manufacturer: \_\_\_\_\_ Type: \_\_\_\_\_ Style/Catalog No.: \_\_\_\_\_ Proposed Setting: \_\_\_\_\_

Manufacturer: \_\_\_\_\_ Type: \_\_\_\_\_ Style/Catalog No.: \_\_\_\_\_ Proposed Setting: \_\_\_\_\_

Manufacturer: \_\_\_\_\_ Type: \_\_\_\_\_ Style/Catalog No.: \_\_\_\_\_ Proposed Setting: \_\_\_\_\_

Manufacturer: \_\_\_\_\_ Type: \_\_\_\_\_ Style/Catalog No.: \_\_\_\_\_ Proposed Setting: \_\_\_\_\_

**Current Transformer Data (if applicable):**

(Enclose copy of Manufacturer’s Excitation & Ratio Correction Curves)

Manufacturer: \_\_\_\_\_ Type: \_\_\_\_\_ Accuracy Class: \_\_\_\_\_ Proposed Ratio Connection: \_\_\_\_\_

Manufacturer: \_\_\_\_\_ Type: \_\_\_\_\_ Accuracy Class: \_\_\_\_\_ Proposed Ratio Connection: \_\_\_\_\_

**Potential Transformer Data (if applicable):**

Manufacturer: \_\_\_\_\_ Type: \_\_\_\_\_ Accuracy Class: \_\_\_\_\_ Proposed Ratio Connection: \_\_\_\_\_

Manufacturer: \_\_\_\_\_ Type: \_\_\_\_\_ Accuracy Class: \_\_\_\_\_ Proposed Ratio Connection: \_\_\_\_\_



**General Technical Detail**

Enclose 3 copies of site electrical One-Line Diagram showing the configuration of all generating facility equipment, current and potential circuits, and protection and control schemes with a Massachusetts Registered Professional Engineer (PE) stamp.

Enclose 3 copies of any applicable site documentation that indicates the precise physical location of the proposed generating facility (e.g. USGS topographic map or other diagram or documentation).

Proposed Location of Protective Interface Equipment on Property:

(Include Address if Different from Application Address)

---

---

Enclose copy of any applicable site documentation that describes and details the operation of the protection and control schemes.

Enclose copies of applicable schematic drawings for all protection and control circuits, relay current circuits, relay potential circuits, and alarm/monitoring circuits (if applicable).

Please enclose any other information to this installation.

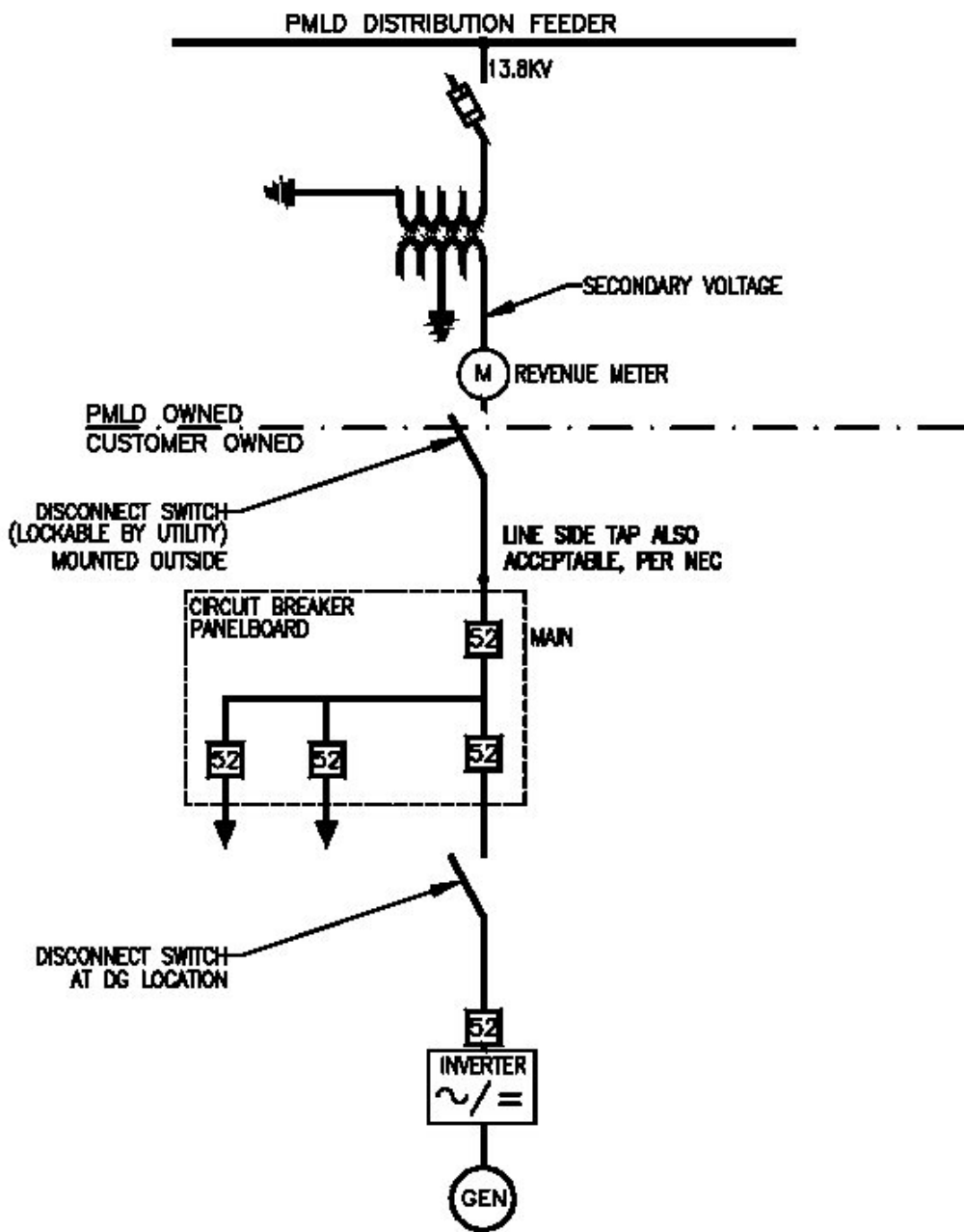

DEVICE	FUNCTION
52	A.C. CIRCUIT BREAKER (LOW VOLTAGE)

INTERCONNECTION REQUIREMENTS 1# INVERTER-BASED GENERATOR LESS THAN 30KW		
PRINCETON MUNICIPAL LIGHT DEPARTMENT PRINCETON, MA		
DWG. B1	REV. 1	DATE 10-2018

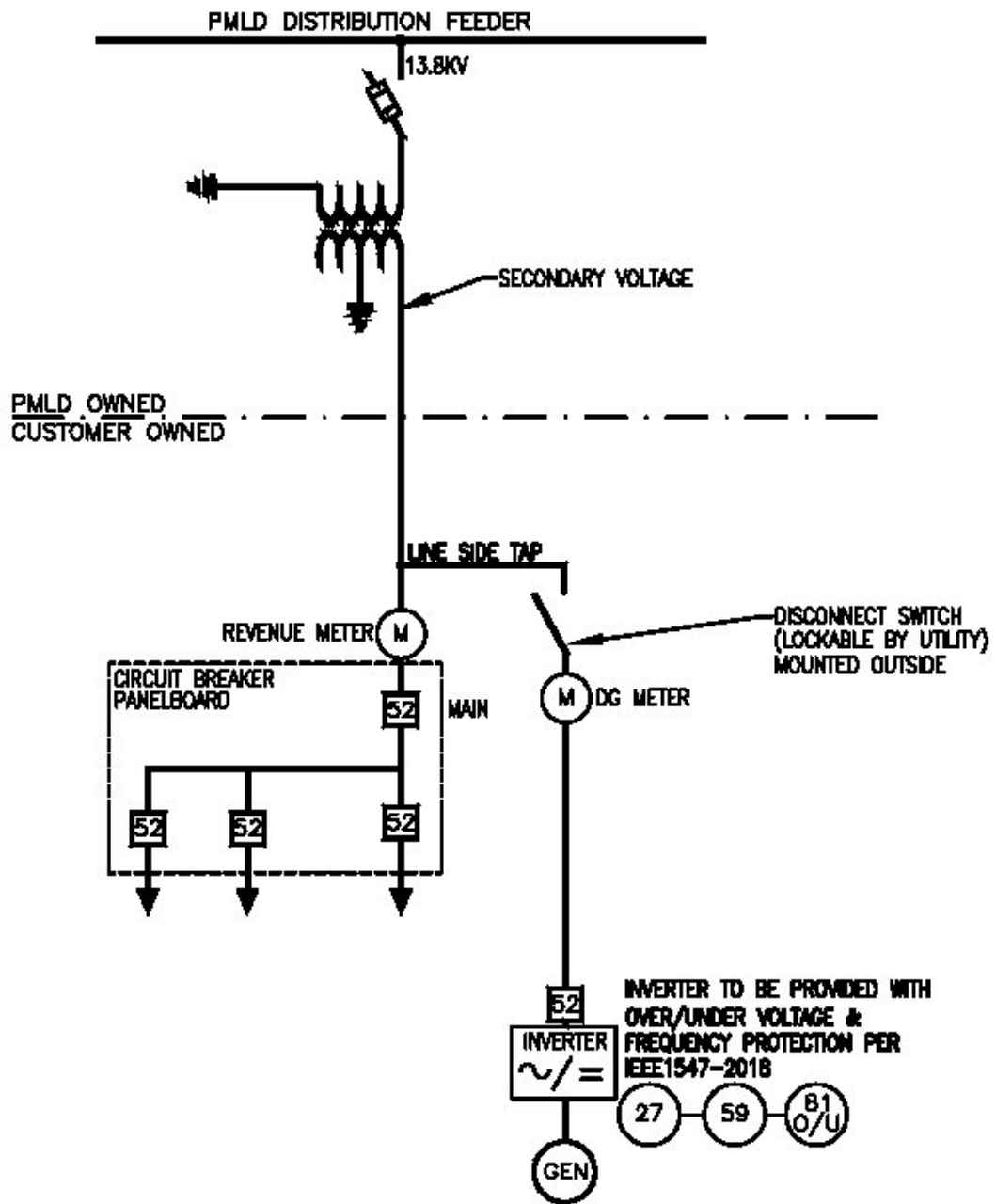

DEVICE	FUNCTION
25	SYNCHRONIZING RELAY
27	UNDervOLTAGE RELAY
52	A.C. CIRCUIT BREAKER (LOW VOLTAGE)
59	OVERVOLTAGE RELAY
81 O/U	OVER/UNDER FREQUENCY RELAY
V.T.	VOLTAGE TRANSFORMER (IF NEEDED)

<b>INTERCONNECTION REQUIREMENTS</b> 1Ø GENERATOR 30KW TO 60KW		
PRINCETON MUNICIPAL LIGHT DEPARTMENT PRINCETON, MA		
DWG. B2	REV. 1	DATE 10-2018

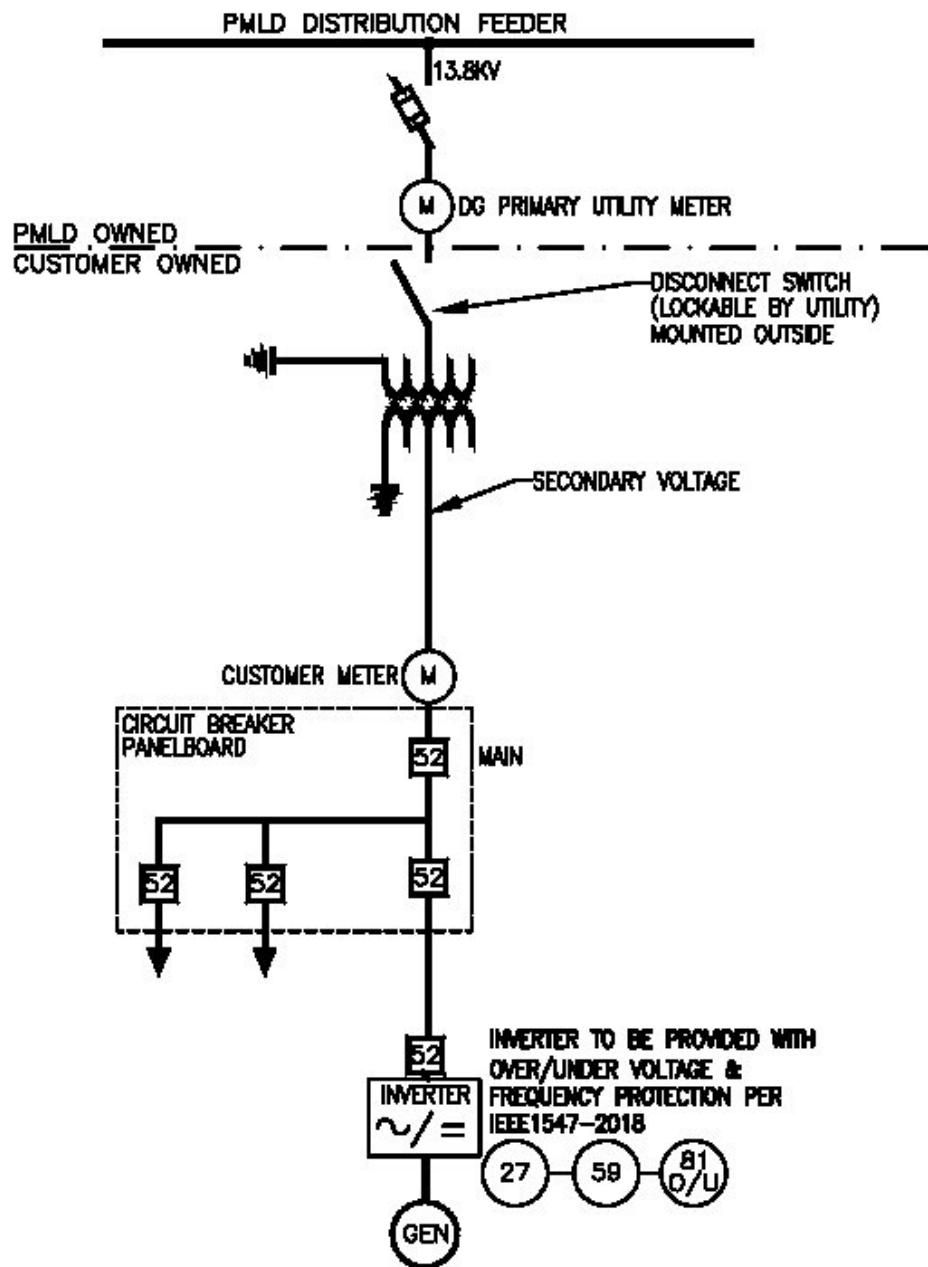

DEVICE	FUNCTION
25	SYNCHRONIZING RELAY
27	UNDERVOLTAGE RELAY
52	A.C. CIRCUIT BREAKER (LOW VOLTAGE)
59	OVERVOLTAGE RELAY
81 O/U	OVER/UNDER FREQUENCY RELAY
51	OVERCURRENT RELAY
51V	VOLT. RESTRAINT TIME OC RELAY
46	NEG. SEQ. OVERCURRENT RELAY
V.T.	VOLTAGE TRANSFORMER (IF NEEDED)

INTERCONNECTION REQUIREMENTS		
3 $\phi$ GENERATOR 60KW TO 499KW		
PRINCETON MUNICIPAL LIGHT DEPARTMENT PRINCETON, MA		
DWG. B3	REV. 1	DATE 10-2018



**Summary of Town of Princeton Municipal Light Department (PMLD)**  
**“Requirements for Interconnection of Non-Utility Generators”**  
**168 Worcester Road, Princeton, MA 01541 (978) 464-2815**

The following is a listing of the major steps required for Customers to interconnection non-utility generators (NUG) and distributed generation (DG) to the PMLD distribution system. *Please refer to the complete interconnection requirements document for additional information.*

1. Interconnecting Customer should complete and submit the Application Form to the PMLD based on the proposed size of the distributed generation (either <30kW for residential customers or ≥30kW for commercial customers).
2. Interconnecting Customer should submit to PMLD copies of drawings, specifications, plans, etc. for proposed installation. PMLD will review the proposed installation to determine potential impact to PMLD distribution system and any required system construction necessary to support DG. See Section 3.0 of the PMLD Interconnection Requirements document.
3. Interconnecting Customer should design DG facility to meet the intent of Section 4.0 of the PMLD Interconnection Requirements document, along with appropriate industry standards, including the National Electric Code and IEEE Std 1547-2018 “*Standard for Interconnecting Distributed Resources with Electric Power Systems*”.
4. PMLD will provide cost estimates for any engineering design, review and construction costs associated with interconnecting the Customer’s DG to the PMLD Electric Power System (EPS). PMLD will also provide an Interconnection Services Agreement for customer signature, prior to the start of any construction on the PMLD EPS. Interconnecting Customer is responsible for the payment of all fees, studies, design and construction costs to interconnect their DG, including costs incurred by PMLD for studies and system modifications.
5. The Interconnecting Customer should consult the PMLD before designing, purchasing and installing any generation equipment, in order to verify the nominal utilization voltages, frequency, and phase characteristics of the service to be supplied, the capacity available, and the suitability of the proposed equipment for operation at the intended location. The following should also be noted:
  - a. Voltage, Frequency, Harmonic and Noise thresholds and limits must be maintained by the DG at all times. See Section 4.0 of the PMLD Interconnection Requirements document and IEEE Std 1547-2018 (or later).
  - b. PMLD will determine protection requirement for each DG project individually. Interconnecting Customer will install protective relaying to control either generator circuit breaker, or utility intertie circuit breaker, in order to trip the generator offline for abnormal conditions, or to prevent reverse power flow into the PMLD EPS (if agreed upon). All relaying shall be designed and set by the Interconnecting Customer and approved by PMLD.
  - c. An external disconnect switch (or compatible device) shall be installed and be accessible to and lockable by PMLD. PMLD shall have the right to open the disconnect switch in accordance with the Interconnection Requirements, or in times of emergency.
6. All facilities will be metered via bi-directional metering, as specification by PMLD. Interconnecting Customer is responsible for installation of metering equipment (sockets, CT’s etc.). PMLD to provide meter.
7. Once the DG facility is constructed and all modifications to the PMLD EPS have been made, the Interconnecting Customer should notify PMLD of their intent to commission the DG. Commissioning of DG equipment shall be in accordance with IEEE Std 1547-2018 and the latest edition of the International Electric Testing Association (NETA) Acceptance Testing Specifications (ATS) documents. PMLD to inspect completed installation and witness commissioning.
8. Authorization to interconnect will be provided once the Interconnecting Customer has met all terms of the interconnection process as outlined in the PMLD Interconnection Requirements document. Interconnecting Customer shall send written notification of completion of installation to PMLD and intent to generate electricity.
9. The Interconnecting Customer shall operate the DG facility in a safe manner with no adverse effects to the PMLD EPS or other Customers. The PMLD will operate the EPS in such a manner so as to not unreasonably interfere with the operation of the Facility. The Interconnecting Customer shall maintain their facility and equipment in accordance with current industry recommendations. PMLD shall have the right to witness or review maintenance tests.